

Type of adjustment set : M18 intermediate hex-rod
M18中間桿調整組

Adjust the length by section (B). After the length setting is completed, tighten nut (A), and then tighten nut (C) finally

使用(B)部份調整，完成後再鎖緊(A)，最後鎖緊(C)

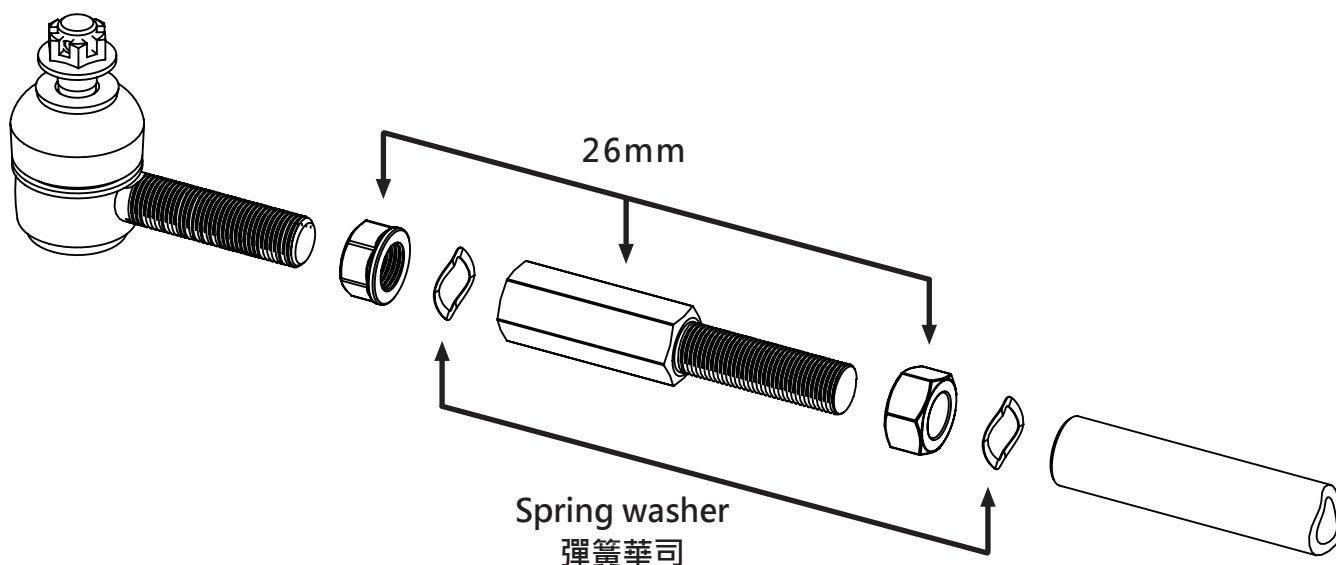

※ Attention! Pillow ball bush and Ball joint must be kept in the middle position.
注意！魚眼及和尚頭必須保持在置中位置

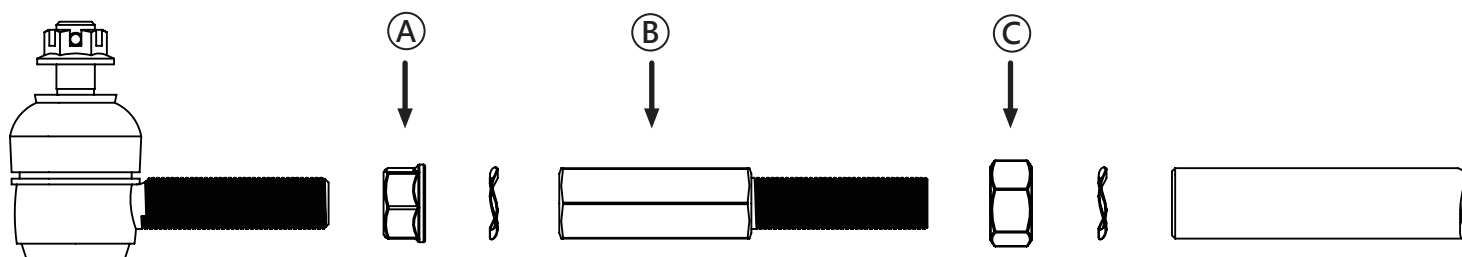

※ Safety adjustment length: 40mm
調整安全長度40mm

